



figure

407

ends
formwafer type
straight

CHECK VALVE

body material	nominal pressure	nominal diameter	max. temperature
A grey cast iron	C 16 bar	DN 50-300	100°C
	B 10 bar	DN 350-400	
I stainless steel	C 16 bar	DN 50-400	150°C



FEATURES

- compact settlement
- environment-friendly
- no maintenance

APPLICATION

- hot and cold water plants
- low-pressure steam plants
- oil plants
- chemical plants
- food plants

Data given can be changed without notice.

Edition 01/2011



figure	407
ends form	wafer type straight

MATERIALS

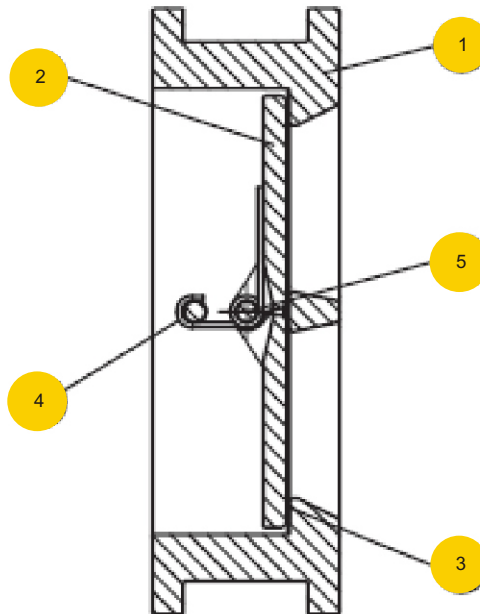

	body material	A		I
	type	56	54	57
1	body	EN-GJL-250 JL1040		X5CrNi18-10
2	plate	EN-GJS-400 JS1030	X5CrNi18-10	X5CrNi18-10
3	seal	EPDM		VITON
4	spring	X5CrNi18-10		X5CrNi18-10
	max. temperature	100°C		150°C

Data given can be changed without notice.

Edition 01/2011



figure

407

ends
form

wafer type
straight

DIMENSIONS

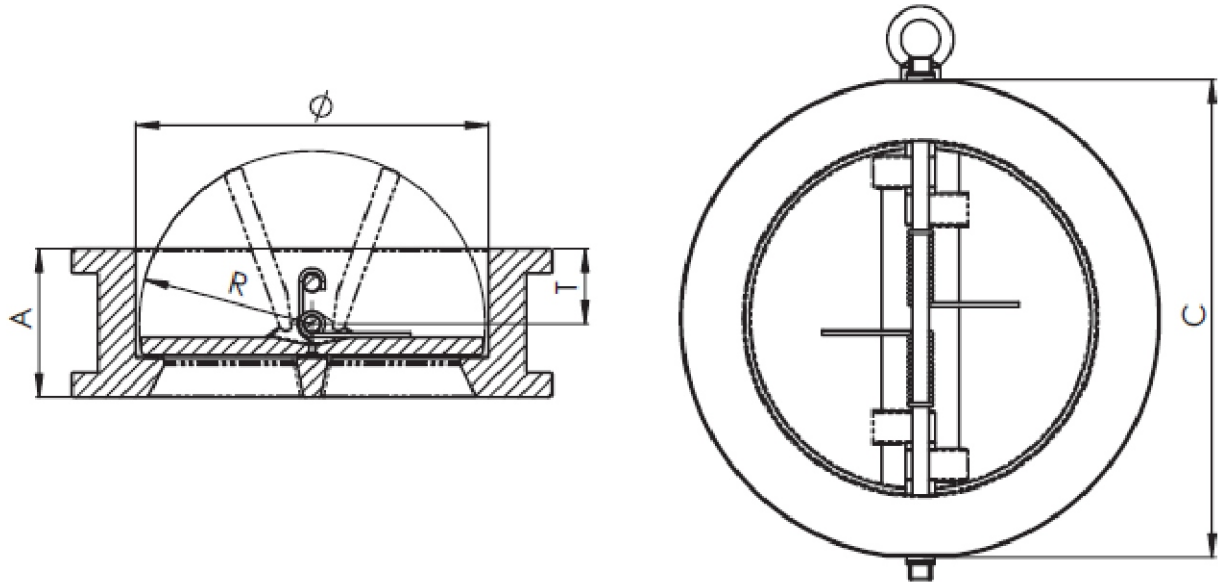

DN	∅	A	C	R	T	Kv	
mm	mm					m ³ /h	kg
50	65	43	107	27	18,4	78	1,3
65	80	46	127	35	19,8	78	2,1
80	94	64	142	42	27,7	130	2,9
100	117	64	162	50	27,7	258	4,3
125	145	70	192	64	30,3	690	6,4
150	171	76	218	77	31,6	690	9,1
200	224	89	273	102,5	32,9	1466	15,2
250	265	114	328	125	50,5	2586	26,5
300	310	114	378	146	43,3	3540	37
350	360	127	446	170	45,3	4610	55
400	410	140	448	195	52,3	6380	80



figure

407

ends
form

wafer type
straight

HYDRAULIC CHARACTERISTICS

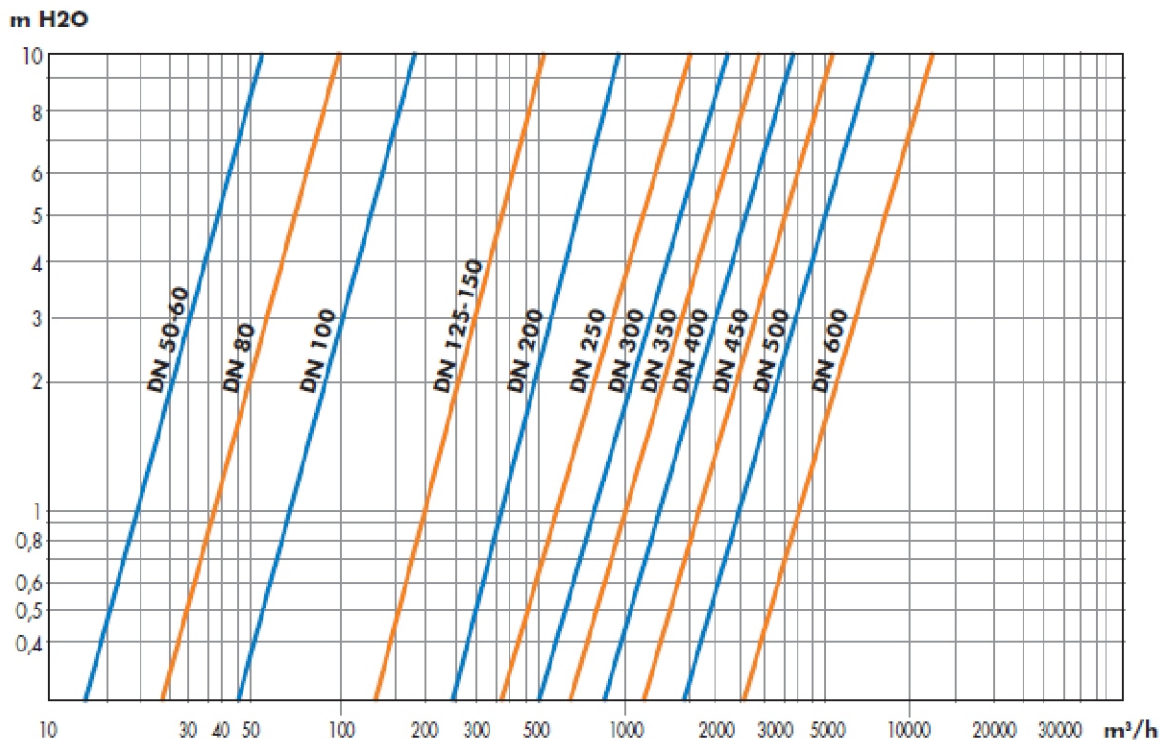

Data given can be changed without notice.

Edition 01/2011



figure	407
ends form	wafer type straight

TYPES

figure	body material	nominal diameter DN	nominal pressure PN	type
407	A grey cast iron EN-GJL-250	50-300 mm	C 16bar	56 Tmax 100 °C * spring - stainless steel * seat ring- EPDM disc - nodular cast iron
		350-400 mm	B 10bar	56 Tmax 100 °C * spring - stainless steel * seat ring- EPDM disc - nodular cast iron
		50-300 mm	C 16bar	54 Tmax 100 °C * disc and spring - stainless steel * seat ring- EPDM
		350-400 mm	B 10bar	54 Tmax 100 °C * disc and spring - stainless steel * seat ring- EPDM
	I stainless steel X5CrNi18 9	50-400 mm	C 16bar	57 Tmax 150 °C * disc, spring and seat ring- stainless steel * seat ring- VITON

ORDERING

To place an order please use our product number (index)



ORDER EXAMPLE

