



figure **917**
ends flange

 **AIR - RELEASE VALVE**



body material	nominal pressure	nominal diameter	max. temperature
A grey cast iron	C 16 bar	DN 25	100°C

FEATURES

- high tightness
- compact settlement
- environment-friendly
- no maintenance
- flanges drilled acc EN 1092-2

APPLICATION

- de-aeration of water pipeline
- montage in the highest point of the pipeline

Data given can be changed without notice.

Edition 01/2011



figure	917
ends	flange

MATERIALS

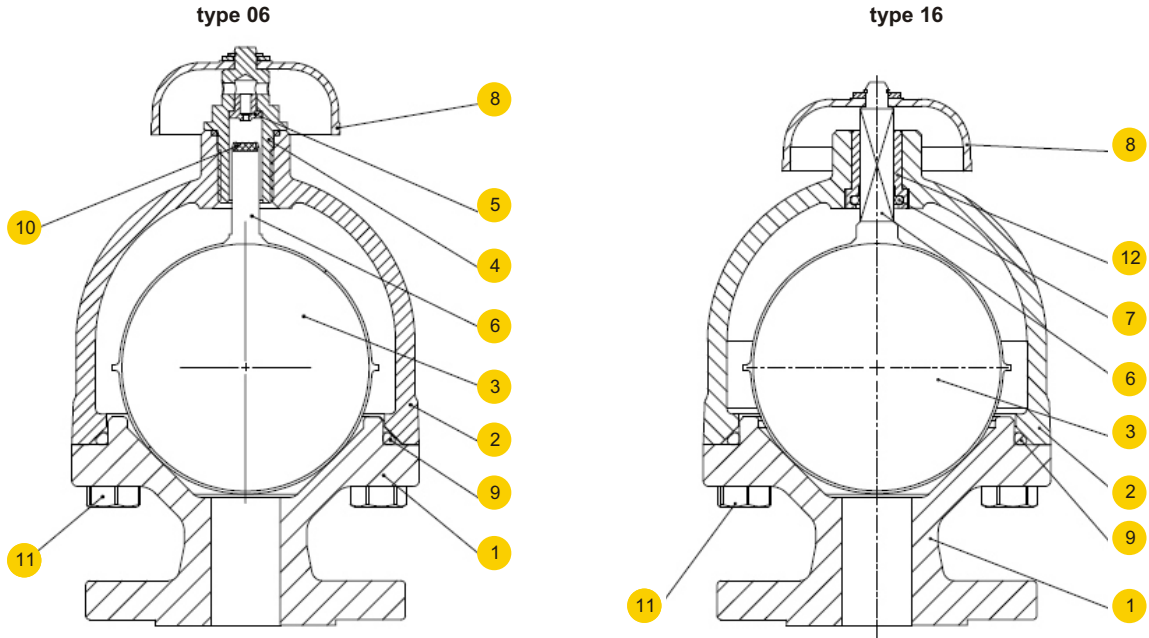

body material		A	
type		06	16
1	body	EN – GJL-250 JL1040	
2	bonnet	EN – GJL-250 JL1040	
3	float	X5CrNi 18-10 1.4301	
4	screw plug	X20Cr13 1.4021	-----
5	nozzle	CuZn40Mn1,5	-----
6	stem	X5CrNi 18-10 1.4301	
7	packing ring	-----	EPDM
8	cup	ABS	
9	packing ring	EPDM	
10	float gasket	EPDM	
11	bolt	8.8 - A2A	
12	sleeve	-----	X5CrNi 18-10 1.4301
max. temperature		100°C	

Data given can be changed without notice.

Edition 01/2011



DIMENSIONS

type 06

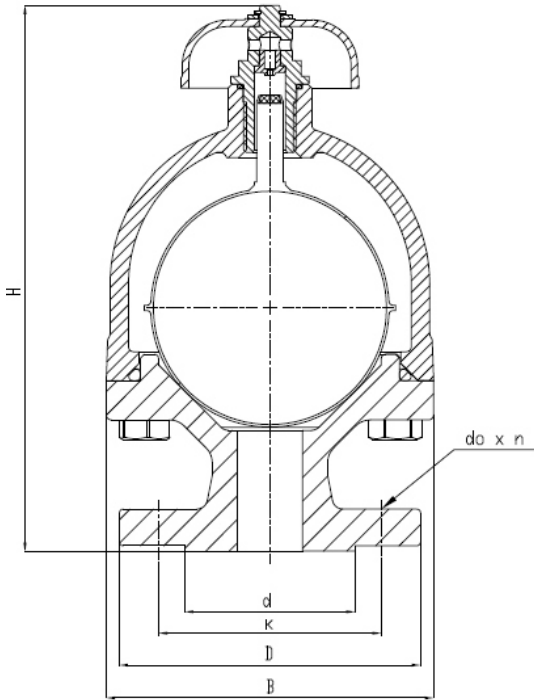

type 16

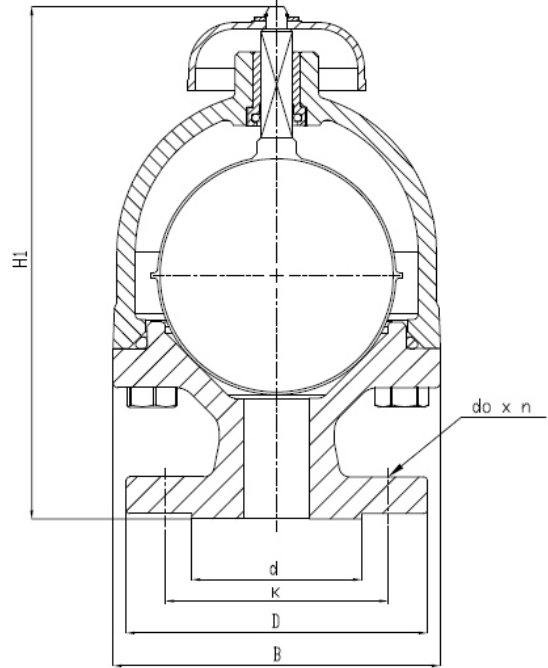

	PN 16 (type 06, 16)						PN 16 (type 06)	PN 16 (type 16)
	B	D	K	d	do x n		H	H1
	kg						mm	
25	122	115	85	65	14x4	5,0	210	205

Data given can be changed without notice.

Edition 01/2011



figure	917
ends	flange

PRESSURE-TEMPERATURE RATINGS

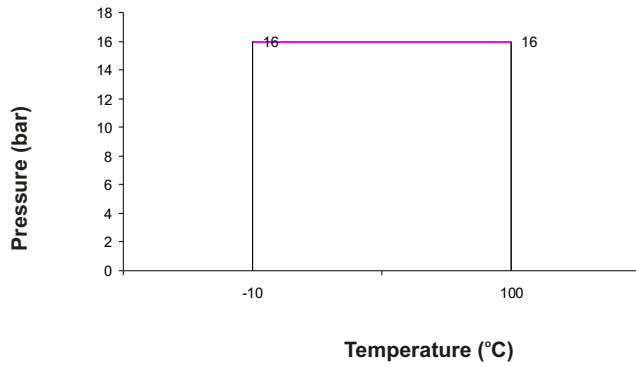

Allowed working conditions range
PN 16 EN-GJL-250



figure	917
ends	flange

TYPES

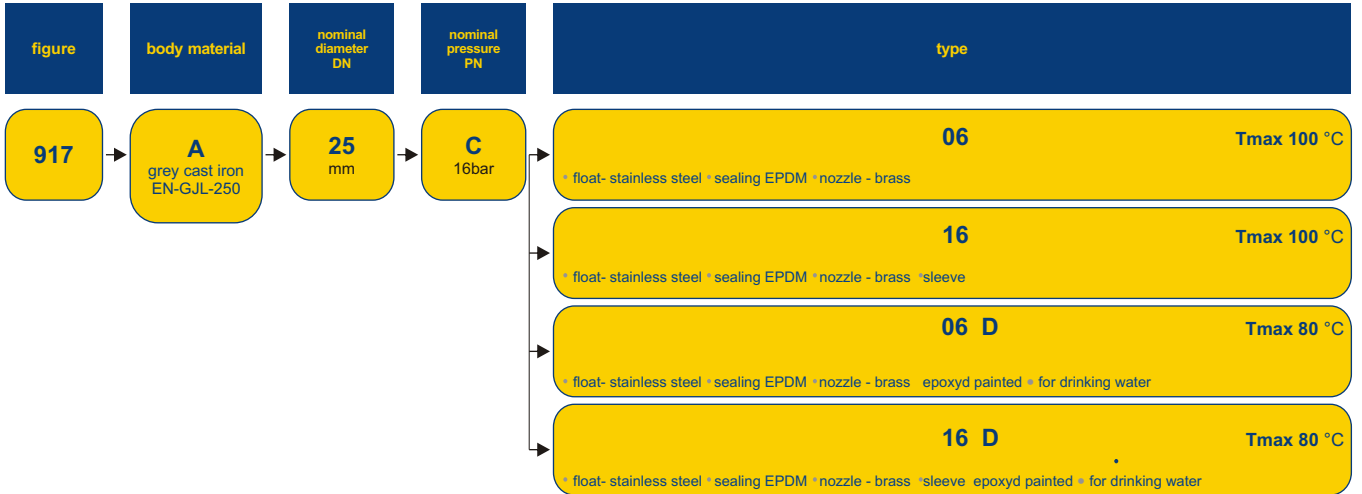

ORDERING

To place an order please use our product number (index)



ORDER EXAMPLE

