

BELLOW VALVE WITH AUMA ACTUATOR zBEL



Body material	Nominal pressure	Nominal diameter	Max. temperature
A Grey cast iron	C 16 bar	DN 65-250	300°C
C Nodular cast iron	C 16 bar D 25 bar	DN 65-250 DN 65-200	350°C



correspond to the pressure equipment directive 2014/68/UE marking CE for DN≥32

FEATURES

- leakproofness class - A wg EN - 12266 – 1 type 01
- leakproofness class IV wg PN-EN 60534-4 type 71
- environment-friendly
- tests acc. EN - 12266 - 1
- flanges drilled according to EN 1092-2
- face-to-face dimension according to EN 558-1 series 1

APPLICATION *

* not all of the applications are suitable for all of the executions

industries						
	INDUSTRY	SHIPBUILDING INDUSTRY	HEATING	REFRIGERATION AND AIR CONDITIONING		
media						
	GLYCOL	INDUSTRIAL WATER	DIATHERMIC OIL	STEAM	COMPRESSED AIR	NEUTRAL FLUIDS

Data given can be changed without notice.

Edition 01/2018

MATERIALS, DIMENSIONS

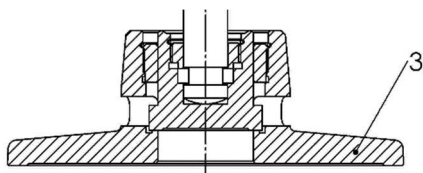
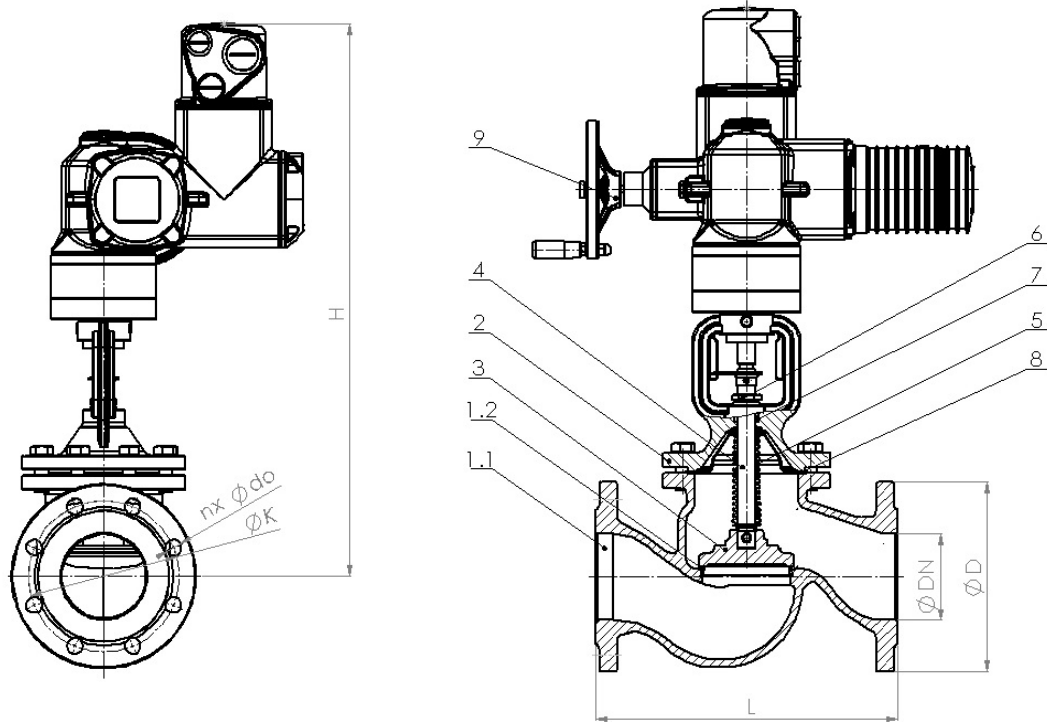

Type 04A DN200-250

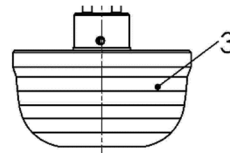

Type 71A DN65-150

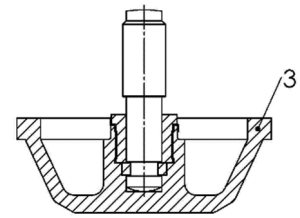

Type 71A DN200-250

Data given can be changed without notice.

Edition 01/2018

ZETKAMA Sp. z o.o.
 Ul. 3 Maja 12
 PL 57-410 Ścinawka Średnia

Tel. +48 74 8652 193
 Tel. +48 74 8652 111
 Fax +48 74 8652 199

E-mail export@zetkama.com.pl
www.zetkama.com

	Body material	A	C
	Type	01A; 04A; 71A	
1.1	Body	EN – GJL-250 5.1301 (ex. JL1040)	EN – GJS-400 – 18-LT 5.3103 (ex.JS1025)
1.2	Seat ring	X12Cr13 1.4006	
2	Bonnet	P235GH 1.0345	
3	Disc	X20Cr13 / X12Cr13 1.4021 / 1.4006	
4	Stem	X20Cr13 1.4021	
5	Bellow	X6CrNiMoTi17-12-2	
6	Gland	Carbon steel	
7	Gland packing	Graphite	
8	Gasket	Graphite	
9	Actuator	AUMA	
	Max. temperature	300°C	350°C

DN	65	80	100	125	150	200	250
L (mm)	290	310	350	400	480	600	730
H (mm)	879	877	665	685	725	910	985

PRESSURE-TEMPERATURE RATINGS

	PN		-10°C÷120°C	150°C	200°C	250°C	300°C	350°C
EN-GJL-250	16	bar	16	14,4	12,8	11,2	9,6	---
EN-GJS-400-18 LT	16		16	15,5	14,7	13,9	12,8	11,2
	25		25	24,3	23	21,8	20	17,5

MAX PERMISSIBLE CLOSING PRESSURES (on flow to open P2=0)

NAPĘD	DN						
	65	80	100	125	150	200	250
AUMA SA 7.2 ; 7.6 – 60Nm	25	25	23	14,9	10,1	5,3	3,3
AUMA SA 10.2 – 120Nm	---	---	---	26,5	18,3	12,3	7,9
AUMA SA 14.2 – 250Nm	---	---	---	---	---	---	---
AUMA SAR 7.2 ; 7.6 – 60Nm	25	25	26,9	17,2	11,9	6,5	4,1
AUMA SAR 10.2 – 120Nm	---	---	---	29,3	20,3	13,7	8,7
AUMA SAR 14.2 – 250Nm	---	---	---	---	---	23,7	15,1

Data given can be changed without notice.

Edition 01/2018

FLANGE DIMENSIONS ACC. PN-EN 1092-1/-2

DN		100	125	150	200	250
PN16	D (mm)	220	250	285	340	405
	K (mm)	180	210	240	295	355
	nxd (mm)	8x19	8x19	8x23	12x23	12x28
PN25	D (mm)	235	270	300	360	-----
	K (mm)	190	220	250	310	-----
	nxd (mm)	8x23	8x28	8x28	12x28	-----

Data given can be changed without notice.

Edition 01/2018

ZETKAMA Sp. z o.o.
Ul. 3 Maja 12
PL 57-410 Ścinawka Średnia

Tel. +48 74 8652 193
Tel. +48 74 8652 111
Fax +48 74 8652 199

E-mail export@zetskama.com.pl
www.zetskama.com

TYPE

Figure	Body material	Nominal diameter	Nominal pressure	Type
234	A Grey cast iron EN-GJL-250	65-150 mm	C 16 bar	stop valve 01A
		200-250 mm	C 16 bar	control valve 71A
		200-250 mm	C 16 bar	stop valve with balancing disc 04A
234	C Nodular cast iron EN-GJS-400-18-LT	65-150 mm	C 16 bar	stop valve 01A
		65-200 mm	C 16 bar	control valve 71A
		200 mm	C 16 bar	stop valve with balancing disc 04A
		65-150 mm	D 25 bar	stop valve 01A
		65-200 mm	D 25 bar	control valve 71A
		200 mm	D 25 bar	stop valve with balancing disc 04A

ORDERING

Figure	Body material	Nominal diameter	Nominal pressure	Type
234	A Grey cast iron EN-GJL-250	65-150 mm	C 16 bar	stop valve 01A

Order example acc. index

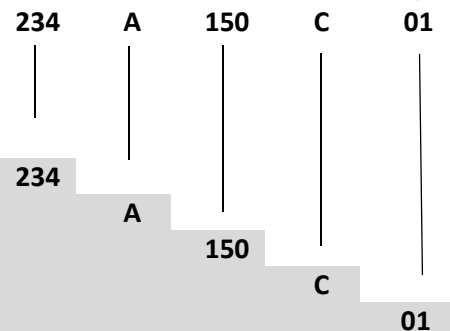

Bellow valve with AUMA actuator
 Grey cast iron EN-GJL-250
 Nominal diameter (mm)
 Nominal pressure PN 16
 Stop valve

Data given can be changed without notice.

Edition 01/2018