



GATE VALVE zGAT



Body material	Nominal pressure	Nominal diameter	Max. temperature
D Nodular cast iron	C 16 bar	DN 40-600*	70°C
	B 10 bar		



***DN650-DN800 on request**

correspond to the pressure equipment directive 2014/68/UE marking CE for DN≥32

FEATURES

- high tightness (leakproofness class - A acc. EN -12266 - 1)
- face of face dimensions: series 14 acc EN 558-1, F4 acc. to DIN 3202
- flange end connections: EN-1092-2
- fusion bonded epoxy coating RAL 5002
- coating thickness: 300µm
- prepared for actuator mounting

APPLICATION

industries



INDUSTRY

media



INDUSTRIAL WATER



NEUTRAL FLUIDS



DRINKING WATER

Data given can be changed without notice.

Edition 01/2021

FIG.111

MATERIALS, DIMENSIONS

DN 40 - 300

DN 350 - 600

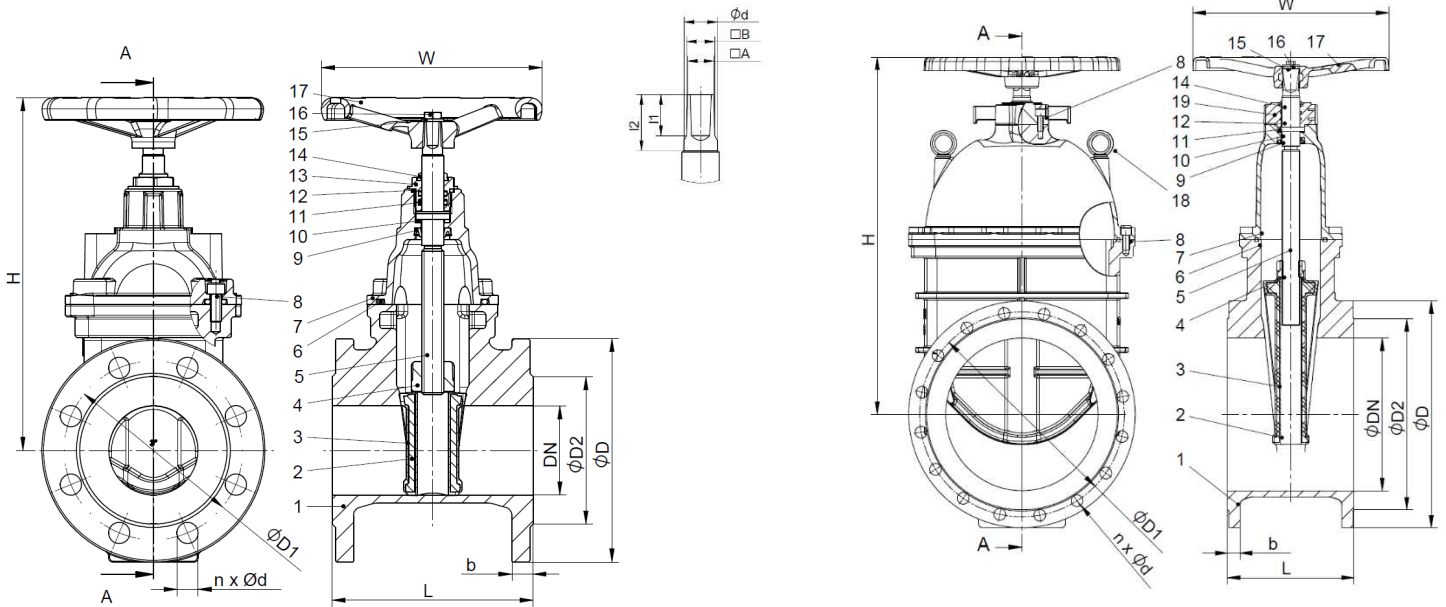

Body material		D			
Type		66	57	56	36
1	Body	EN-GJS-500-7 5.3200 (ex.JS1050)			
2	Wedge	EN-GJS-500-7 5.3200 (ex.JS1050)			
3	Cover of wedge	EPDM			
4	Threaded bush	CuZn36Pb2As			
5	Stem	X20Cr13			
6	Cover seal	EPDM			
7	Cover	EN-GJS-500-7 5.3200 (ex.JS1050)8.8			
8	Bolt	C15, C15R, C15E			
9	seal ring	EPDM			
10	Washer	Nylon			
11	O-ring	EPDM			
12	O-ring	EPDM			
13	Thrust bearing	CuZn36Pb2As			
14	Seal	NBR/EPDM			
15	Washer	-	C15, C15R, C15E		-
16	Nut	-	C15, C15R, C15E		-
17	Hand wheel	-	EN-GJS-500-7 5.3200 (ex.JS1050)8.8		-
18	nut	-	C15, C15R, C15E		
19	Cover	-	EN-GJS-500-7 5.3200 (ex.JS1050)		
Max. temperature		70°C			

Data given can be changed without notice.

Edition 01/2021

FIG.111

DN	40	50	65	80	100	125	150	200	250	300	350	400	450	500	600
L (mm)	140	150	170	180	190	200	210	230	250	270	290	310	330	350	390
H (mm)	235	240	250	312	335	385	438	543	645	728	812	923	974	1073	1254
D (mm)	PN10	-	-	-	-	-	-	340	400	455	505	565	615	670	780
	PN16	150	165	185	200	220	250	285	340	405	460	520	580	640	840
D1 (mm)	PN10	-	-	-	-	-	-	295	350	400	460	515	565	620	725
	PN16	110	125	145	160	180	210	240	295	355	410	470	525	585	770
D2 (mm)	84	99	118	132	156	184	211	266	319	370	429	480	548	609	720
b (mm)	PN10	-	-	-	-	-	-	20	22	24,5	24,5	24,5	25,5	26,5	30,0
	PN16	19	19	19	19	19	19	20	22	24,5	26,5	28,0	30,0	31,5	36,0
n (mm)	PN10	-	-	-	-	-	-	8	12	12	16	16	20	20	20
	PN16	4	4	4	8	8	8	8	12	12	12	16	16	20	20
d (mm)	PN10	-	-	-	-	-	-	23	23	23	23	28	28	28	31
	PN16	19	19	19	19	19	19	23	23	28	28	28	31	31	34
W (mm)	160	160	160	200	250	250	320	320	320	360	600	600	600	730	730
C (mm)	5,0	5,0	5,0	5,0	6,0	6,0	7,0	7,5	9,0	10,0	14	16	17	18	18
□ A (mm)	12,8	12,8	12,8	14,5	17,0	17,2	18,7	20,0	20,0	20,0	30,0	30,0	35,0	35,0	35,0
□ B (mm)	13,8	13,8	13,8	15,6	19,5	19,7	21,7	22,0	22,0	22,0	-	-	-	-	-
φd (mm)	17	17	17	18	24	24	24	26	26	28	38	38	42	45	45
I1 (mm)	20	20	20	22	25	25	30	30	30	30	45	45	45	45	45
I2 (mm)	28	28	28	27	32	32	40	40	40	40	66	60	130	60	60
Weight (kg)															
111	PN10	-	-	-	-	-	-	58,0	85,0	131,0	182,6	262,4	320,0	400,0	630,0
	PN16	8,0	9,0	11,8	14,2	18,6	26,6	36,2	58,4	85,4	132,0	182,6	262,4	320,0	400,0

TYPE 66 FOR ACTUATOR DN 40-DN 300

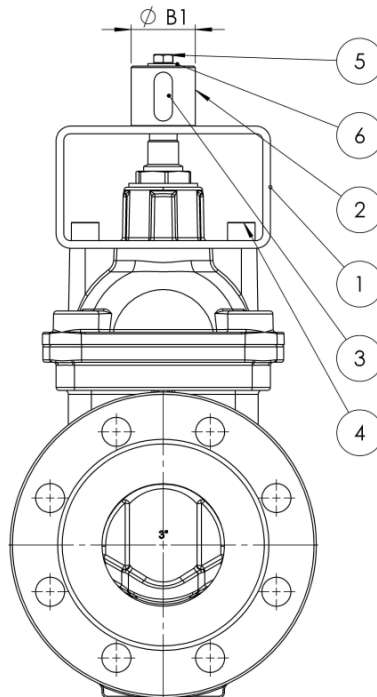

Data given can be changed without notice.

Edition 01/2021

ZETKAMA Sp. z o.o.
Ul. 3 Maja 12
PL 57-410 Ścinawka Średnia

Tel. +48 74 8652 193
Tel. +48 74 8652 111
Fax +48 74 8652 199

E-mail export@zetkama.com.pl
www.zetkama.com

FIG.111

THE DIMENSIONS AND THE LIST OF THE MAIN ELEMENTS FOR MOUNTING THE ACTUATOR

DN	40	50	65	80	100	125	150	200	250	300	List of parts
Bracket. Drilling acc. ISO 5210	F10	F10	F10	F10	F10	F10	F10	F10	F14	F14	1
Joint acc. ISO 5210 / B1 Ød mm	42	42	42	42	42	42	42	42	60	60	2
Parallel key	12x8x32	12x8x32	12x8x32	12x8x32	12x8x32	12x8x32	12x8x32	12x8x32	18x11x5 0	18x11x5 0	3
Bolt EN ISO 4762	2szt. M12x16 8.8	2szt. M12x16 8.8	2szt. M12x16 8.8	2szt. M12x16 8.8	2szt. M12x16 8.8	4szt. M10x16 8.8	4szt. M10x16 8.8	4szt. M10x16 8.8	4szt. M16x18 8.8	4szt. M16x18 8.8	4
Bolt EN ISO 4017	M8x35	M8x35	M8x35	M8x35	M10x35	M10x35	M10x35	M10x35	M12x50	M12x50	5
Pillow ISO 7094	M8	M8	M8	M8	M8	M10	M10	M10	M12	M12	6
Operating torque Nm	12	25	30	50	55	60	80	110	150	200	
Number of turns to complete closure	13	19	19	26	25	32	33	44	55	53	

DN 40 – 300 with actuator AUMA

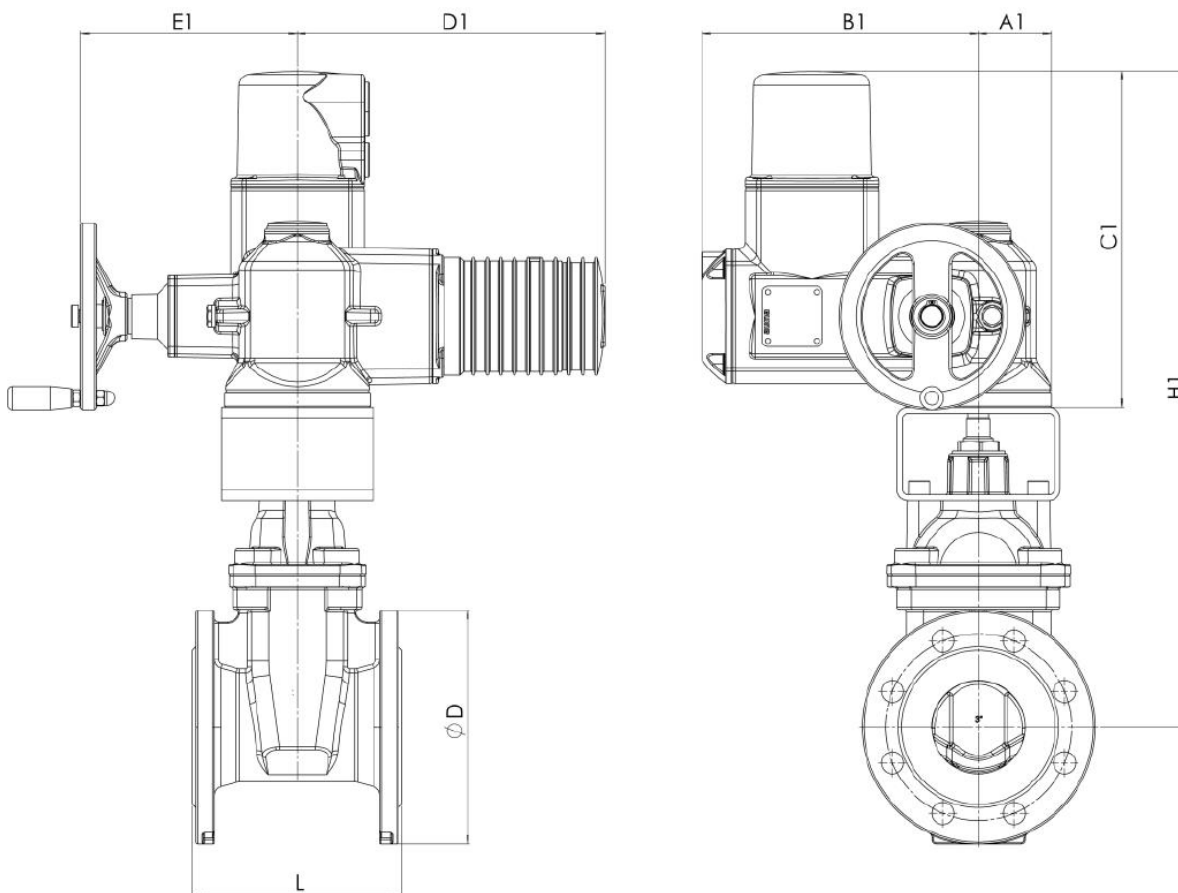

Data given can be changed without notice.

Edition 01/2021

FIG.111

DN	40	50	65	80	100	125	150	200	250	300
Actuator	SA 07.2	SA 07.2	SA 07.6	SA 07.6	SA 07.6	SA 10.2	SA 10.2	SA 10.2	SA 14.2	SA 14.2
PN (MPa)	1,6	1,6	1,6	1,6	1,6	1,6	1,6	1,0/1,6	1,0/1,6	1,0/1,6
A1 (mm)	62	62	62	62	62	65	65	65	91	91
B1 (mm)	238	238	238	238	238	248	248	248	286	286
E1 (mm)	186	186	186	186	186	191	191	191	242	242
D1 (mm)	265	265	265	265	265	283	283	283	389	389
H1 (mm)	459	493	498	559	593	643,5	684	779	914	991
C1 (mm)	288	288	288	288	288	290	290	290	316	316
øD (mm)	150	165	185	200	220	250	285	340	400/405	455/460
L (mm)	140	150	170	180	190	200	210	230	250	270

TYPE 36 FOR ACTUATOR DN350-DN800

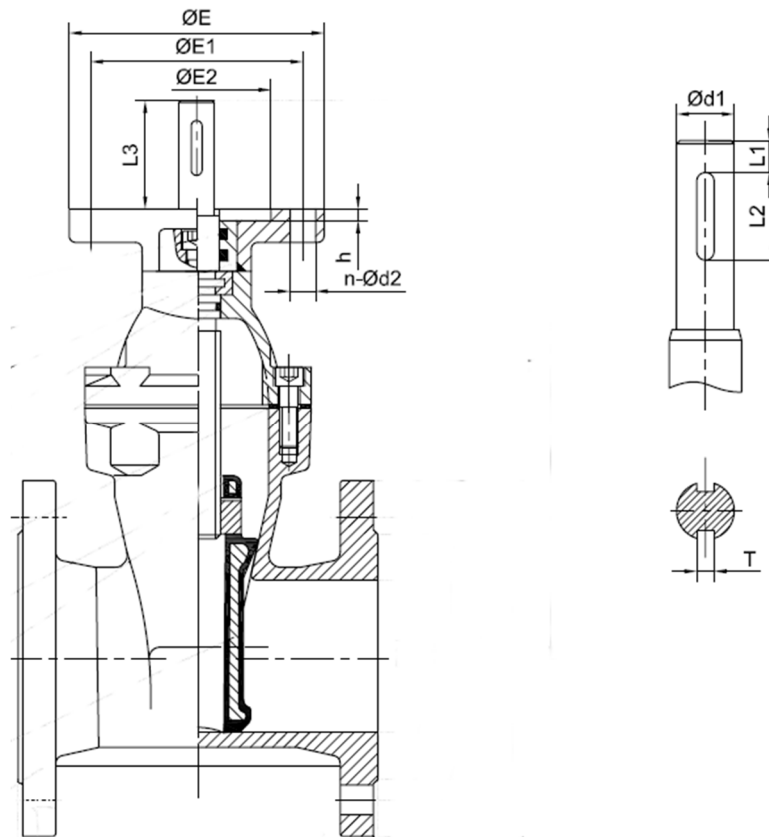

DN	Top flange	ØE	ØE1	ØE2	h	n-ød2	ød1	L3	L1	T	L2
350	F14	175	140	100	4,5	4-18	30	65	5	8	60
400	F14	175	140	100	4,5	4-18	30	65	5	8	60
450	F14	175	140	100	4,5	4-18	30	65	5	8	60
500	F14	175	140	100	4,5	4-18	30	65	5	8	60
600	F14	175	140	100	4,5	4-18	30	65	5	8	60
700	F16	210	165	130	5,5	4-22	40	80	5	12	63
800	F25	300	254	200	5,5	8-18	50	100	10	14	70

Data given can be changed without notice.

Edition 01/2021

ZETKAMA Sp. z o.o.
 Ul. 3 Maja 12
 PL 57-410 Ścinawka Średnia

Tel. +48 74 8652 193
 Tel. +48 74 8652 111
 Fax +48 74 8652 199

E-mail export@zetskama.com.pl
www.zetskama.com

FIG.111

Closing moment

DN	350	400	450	500	600	700	800
Nm	370	430	470	500	600	800	1200

The number of turns to fully close

DN	350	400	450	500	600	700	800
Turn	30	35	40	45	50	50	57

DN 350-600 with actuator AUMA

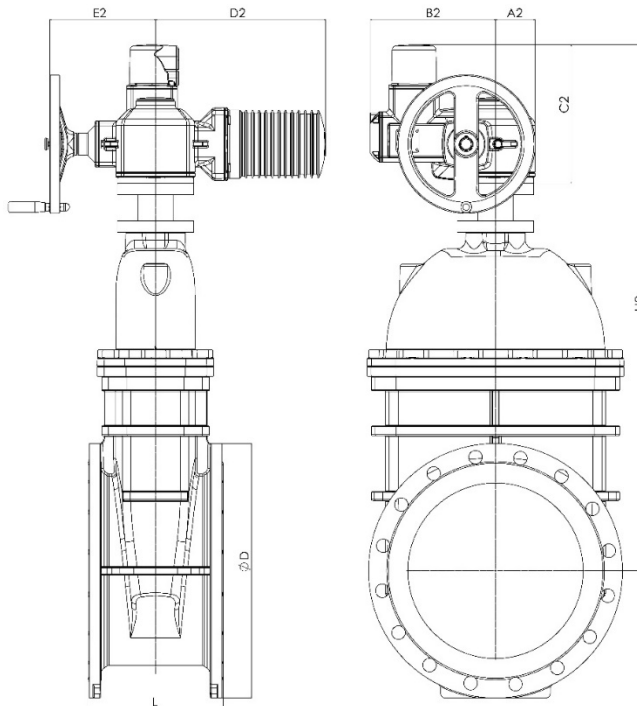

DN	350	400	450	500	600
actuator	SA 14.6	SA 14.6	SA 14.6	SA 14.6	SA 14.6
PN (MPa)	1,0/1,6	1,0/1,6	1,0/1,6	1,0/1,6	1,0/1,6
A2 (mm)	91	91	91	91	91
B2 (mm)	286	286	286	286	286
E2 (mm)	245	245	245	245	245
D2 (mm)	389	389	389	389	389
H2 (mm)	1091	1199	1271	1381	1551
H1-C1	665+110	773+110	845+110	925+140	1095+140
C2 (mm)	316	316	316	316	316
$\varnothing D$ (mm)	505/520	565/580	615/640	670/715	780/840
L (mm)	290	310	330	350	390

Data given can be changed without notice.

Edition 01/2021

FIG.111

TYPE

Figure	Body material	Nominal diameter	Nominal pressure	Type
111	D Nodular cast iron EN-GJS-500-7	40-300 mm	C 16 bar	57 inside threaded stem, smooth port EPDM, cast iron/EPDM Wedge, epoxy paint, with hand wheel, universal cover
		350-600 mm	C 16 bar	56 inside threaded stem, smooth port EPDM, cast iron/EPDM Wedge, epoxy paint, with hand wheel,
		40-800 mm	C 16 bar	36 inside threaded stem, smooth port EPDM, cast iron/EPDM Wedge, epoxy paint, cover prepared for mounting the actuator
		40-300 mm	B 10 bar	57 inside threaded stem, smooth port EPDM, cast iron/EPDM Wedge, epoxy paint, with hand wheel, universal cover
		350-600 mm	B 10 bar	56 inside threaded stem, smooth port EPDM, cast iron/EPDM Wedge, epoxy paint, with hand wheel,
		40-800 mm	B 10 bar	36 inside threaded stem, smooth port EPDM, cast iron/EPDM Wedge, epoxy paint, cover prepared for mounting the actuator
		40-300 mm	C 16 bar	66 inside threaded stem, smooth port EPDM, cast iron/EPDM Wedge, epoxy paint, without hand wheel, universal cover

ORDERING

Figure	Body material	Nominal diameter	Nominal pressure	Type
111	D Nodular cast iron EN-GJS-500-7	40-300 mm	C 16 bar	57 inside threaded stem, smooth port EPDM, cast iron/EPDM Wedge, epoxy paint, with hand wheel, universal cover

Order example acc. index

111 D 050 C 57

Gate valves, ends flange, form straight

Nodular cast iron EN-GJS-500-7

Nominal diameter (mm)

Nominal pressure PN 16

Inside threaded stem, smooth port EPDM, cast iron/EPDM Wedge, epoxy paint, with hand wheel universal cover

111

D

050

C

57

Data given can be changed without notice.

Edition 01/2021