

BELLOW VALVE zBEL



Body material	Nominal pressure	Nominal diameter	Max. temperature
A Grey cast iron	C 16 bar	DN 15-250	300°C
C Nodular cast iron	C 16 bar D 25 bar	DN 15-200 DN 15-80	350°C

correspond to the pressure equipment directive 2014/68/UE marking CE for DN≥32



FEATURES

- high tightness (leakproofness class - A acc. EN -12266 - 1)
- compact settlement
- environment-friendly
- tests acc. EN - 12266 - 1
- flanges drilled according to EN 1092-2 for body material A,C
- face-to-face dimension according to EN 558 series 8

APPLICATION *

*not all of the applications are suitable for all of the executions

industries						
	INDUSTRY	SHIPBUILDING INDUSTRY	HEATING	REFRIGERATION AND AIR CONDITIONING	CHEMICAL INDUSTRY	
media						
	GLYCOL	INDUSTRIAL WATER	DIATHERMIC OIL	STEAM	COMPRESSED AIR	NEUTRAL FLUIDS

Data given can be changed without notice.

Edition 01/2020

MATERIALS, DIMENSIONS

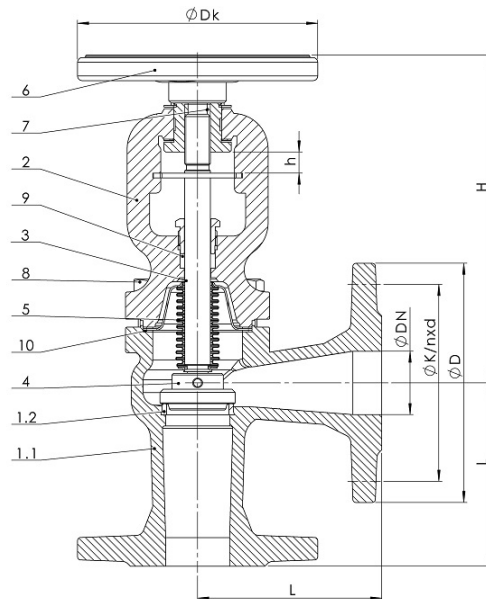

	Body material	A	C
	Type	01; 04; 71	01; 04; 71
1.1	Body	EN – GJL-250 5.1301 (ex. JL1040)	EN – GJS-400 – 18-LT 5.3103 (ex.JS1025)
1.2	Seat ring	X12Cr13 1.4021	
2	Bonnet	EN – GJS-400 – 18-LT 5.3103 (ex.JS1025)	
3	Stem	X20Cr13 1.4021	
4	Disc	X20Cr13+GT 1.4021	
5	Bellow	X6CrNiMoTi-17-12-2	
6	Hand-wheel	Steel	
7	Sleeve	11SMnPb30	
8	Hexagon bolt	5.6 A3A	A2-70
9	Gland packing	Graphite	
10	Bonnet gasket	Graphite + CrNiSt	
	Max. temperature	300°C	350°C

DN	15	20	25	32	40	50	65	80	100	125	150	200	250	
L (mm)	90	95	100	105	115	125	145	155	175	200	225	275	325	
Dk (mm)	125	125	125	125	150	150	175	200	250	300	400	500	500	
H (mm)	181	178	192	188	205	211	242	251	307	337	366	493	531	
h (mm)	5	5	7	8	10	13	17	20	25	32	38	50	63	
K _{vs} (m ³ /h)	01;04	7,2	9,2	16,0	22,0	37,0	51,0	98,5	143,0	226,0	291,0	455,0	625,0	-----
	71	3,3	6,3	9,0	16,3	24,4	32,7	57,9	84,1	133,9	206,5	291,1	569,0	-----
Weight (kg)	01;04	3,2	3,7	4,9	6,5	8,8	9,7	13,8	18,0	31,0	44,0	69,0	110,5	-----
	71	3,2	3,9	5,0	6,7	9,1	10,2	14,3	18,9	33,0	46,5	71,0	-----	-----

Data given can be changed without notice.

Edition 01/2020

ZETKAMA Sp. z o.o.
Ul. 3 Maja 12
PL 57-410 Ścinawka Średnia

Tel. +48 74 8652 193
Tel. +48 74 8652 111
Fax +48 74 8652 199

E-mail export@zetskama.com.pl
www.zetskama.com

PRESSURE-TEMPERATURE RATINGS

Acc EN 1092-2	PN		-60°C ÷ <-10°C	-10°C ÷ 120°C	150°C	200°C	250°C	300°C	350°C	400°C	450°C
EN-GJL250	6	bar	----	6	5,4	4,8	4,2	3,6	---	---	---
	16		-----	16	14,4	12,8	11,2	9,6	---	---	---
EN-GJS400-18 LT	16		-----	16	15,5	14,7	13,9	12,8	11,2	---	---
	25		-----	25	24,3	23	21,8	20	17,5	---	---

FLANGE DIMENSIONS ACC. PN-EN 1092-2

DN		15	20	25	32	40	50	65	80	100	125	150	200	250
PN16	D (mm)	95	105	115	140	150	165	185	200	220	250	285	340	405
	K (mm)	65	75	85	100	110	125	145	160	180	210	240	295	355
	nxd (mm)	4x14	4x14	4x14	4x19	4x19	4x19	4x19	8x19	8x19	8x19	8x23	12x23	12x28
PN25	D (mm)	95	105	115	140	150	165	185	200	-----	----	-----	-----	-----
	K (mm)	65	75	85	100	110	125	145	160	-----	-----	-----	-----	-----
	nxd (mm)	4x14	4x14	4x14	4x19	4x19	4x19	8x19	8x19	-----	-----	-----	-----	-----

DISC

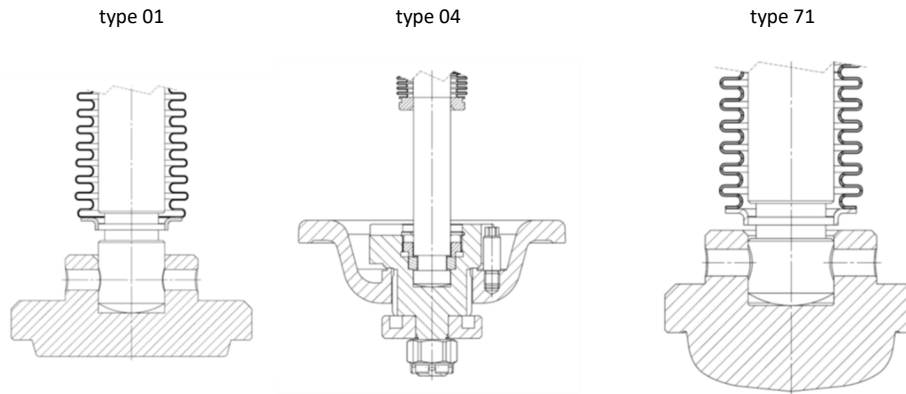

Other type of valves on request:

- stellite seat
- hardened disc
- other

Data given can be changed without notice.

Edition 01/2020

TYPE

Figure	Body material	Nominal diameter	Nominal pressure	Type
235	A Grey cast iron EN-GJL-250	15-150 mm	C 16 bar	01 stem connected with bellow; stem, disc, bellow and seat ring - stainless steel
		200-250 mm	C 16 bar	04 stem connected with bellow; stem, balancing disc; bellow and seat ring - stainless steel
		15-200 mm	C 16 bar	71 stem connected with bellow; stem, throttling disc; bellow and seat ring - stainless steel
235	C Nodular cast iron EN-GJS-400-18-LT	15-150 mm	C 16 bar	01 stem connected with bellow; stem, disc, bellow and seat ring - stainless steel
		200 mm	C 16 bar	04 stem connected with bellow; stem, balancing disc; bellow and seat ring - stainless steel
		15-200 mm	C 16 bar	71 stem connected with bellow; stem, throttling disc; bellow and seat ring - stainless steel
		15-80 mm	D 25 bar	01 stem connected with bellow; stem, disc, bellow and seat ring - stainless steel
		15-80 mm	D 25 bar	71 stem connected with bellow; stem, throttling disc; bellow and seat ring - stainless steel

ORDERING

Figure	Body material	Nominal diameter	Nominal pressure	Type
235	A Grey cast iron EN-GJL-250	15-150 mm	C 16 bar	01 stem connected with bellow; stem, disc, bellow and seat ring - stainless steel

Order example acc. index

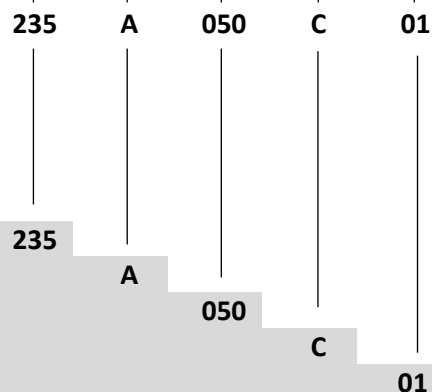

Bellow sealed stop valves, ends flanged, form angle
 Grey cast iron EN-GJL-250
 Nominal diameter (mm)
 Ciśnienie nominalne PN 16
 Stem connected with bellow; stem, disc and seat ring stainless steel

Data given can be changed without notice.

Edition 01/2020

