

BUTTERFLY VALVE zBUT



Body material	Nominal pressure	Nominal diameter	Max. temperature
A Grey cast iron	C 16 bar	32-150	210°C*
	B 10 bar	200-1200	
B Nodular cast iron	C 16 bar	32-150	
	B 10 bar	300-1200	

* max. temperature depends on the used materials



correspond to the pressure equipment directive 2014/68/UE marking CE for DN≥32

FEATURES

- high tightness class - A acc. to EN - 12266 – 1
- vulcanized seat, the possibility of use in systems with vacuum
- compact settlement
- environment-friendly
- tests acc. to EN - 12266 - 1
- face-to-face dimension according to EN 558 series 20
- Epoxy RAAL 5002 150 μm
- sealing EPDM/ NBR/ FLUCAST/ SILICONE/ VITON/ HYPALON/ EPICHLOROHYDRIN/ NEOPREN/ BUTYL
- discs NODULAR CAST IRON/ STAINLESS STEEL/ ALUMINIUM/ BRONZE/ ALU-BRONZE/ CAST STEEL/ DUPLEX/ SUPERDUPLEX

APPLICATION *

* not all of the applications are suitable for all of the executions

industries								
	INDUSTRY	SHIPBUILDING INDUSTRY	FOOD INDUSTRY	CHEMICAL INDUSTRY	HEATING	REFRIGERATION AND AIR CONDITIONING	PETROCHEMICAL INDUSTRY	POWER ENGINEERING
media								
	GLYCOL	SEWAGE	DRINKING WATER	STEAM	INDUSTRIAL WATER	COMPRESSED AIR	NEUTRAL FLUIDS	

Data given can be changed without notice.

Edition 01/2018

MATERIALS, DIMENSIONS

DN32-500

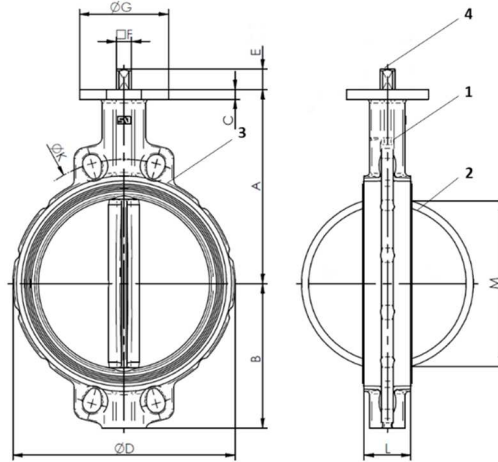

Body material		B					
Type		26-I	66-I	C6-I	O6-I	36-I	A6-I
1	Body *	EN-GJS-400-15 5.3106 (ex.JS1030 + Epoxy)					
2	Disc**	EN-GJS-400-15 5.3106 (ex.JS1030 + Epoxy)			1.4408		
3	Seat***	EPDM					
4	Stem	1.4005					
Operation		Bare shaft	Catch lever	Gear box	Bare shaft	Catch lever	Gear box
Max. temperature		110°C					

* other body materials on request

** other disc materials on request

*** other seat materials on request

DN	32	40	50	65	80	100	125	150	200	250	300	350	400	450	500
A (mm)	103	110	120	135	141	165	180	193	225	283	308	339	380	381	433
B (mm)	60	58	61	69	94	106	126	133	170	210	240	263	308	340	380
C (mm)	8	10	10	10	10	10	12	12	12	14	14	16	18	20	20
D (mm)	68	76	100	108	124	147	180	206	257	324	376	422	480	536	593
E (mm)	30	30	30	30	30	30	33	33	33	30	30	31	31	38	38
F (mm)	11	11	11	11	11	11	14	14	17	22	22	22	27	36	36
G (mm)	90	90	90	90	90	90	90	90	90	130	130	160	160	190	210
K (mm) (PN16)	100	110	125	145	160	180	210	240	295	355	410	470	525	585	650
M (mm)	14	26	29	46	65	90	112	139	191	241	290	338	387	434	478
L (mm)	33	33	43	46	46	52	56	56	60	68	78	78	102	114	127
ISO	F-07	F-07	F-07	F-07	F-07	F-07	F-07	F-07	F-07	F-10	F-10	F-10	F-10	F-12	F-14
Operating torque (Nm)	15	15	17	25	28	50	85	110	140	270	390	500	897	1450	1800
Weight (kg)	1,5	1,6	2,4	2,7	3,2	4,0	6,2	7,3	11	20	30	35	56	80	114

Data given can be changed without notice.

Edition 01/2018

ZETKAMA Sp. z o.o.
Ul. 3 Maja 12
PL 57-410 Ścinawka Średnia

Tel. +48 74 8652 193
Tel. +48 74 8652 111
Fax +48 74 8652 199

E-mail export@zetskama.com.pl
www.zetskama.com

FIG.495

DN600-1200

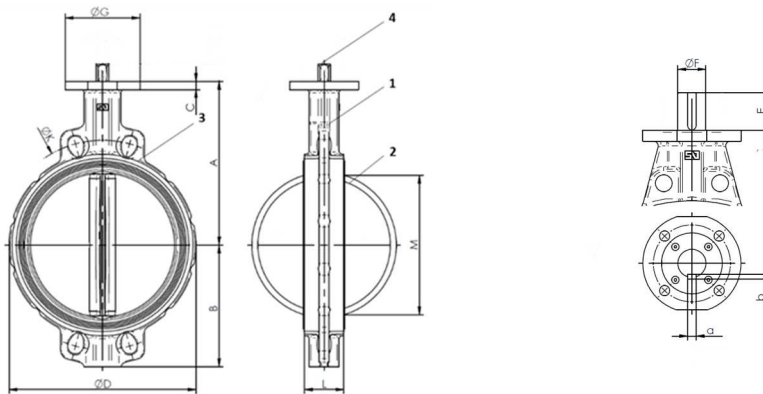

Body material		B			
Type		26-I	C6-I	06-I	A6-I
1	Body *	EN-GJS-400-15 5.3106 (ex.JS1030 + Epoxy)			
2	Disc**	EN-GJS-400-15	5.3106 (ex.JS1030 + Epoxy)	1.4408	
3	Seat***	EPDM			
4	Stem	1.4005			
operation		Bare shaft	Gear box	Bare shaft	Gear box
Max. temperature		110°C			

* other body materials on request

** other disc materials on request

*** other seat materials on request

DN	600	700	750	800	900	1000	1100	1200
A (mm)	494	560	580	630	695	770	815	875
B (mm)	440	485	530	565	610	675	733	818
C (mm)	24	25	25	27	32	32	32	40
D (mm)	690	780	836	902	1010	1116	1215	1334
E (mm)	80	106	106	106	110	110	110	110
F (mm)	210	300	300	300	350	350	350	350
G (mm)	210	300	300	300	350	350	350	350
K (mm) (PN10)	725	840	900	950	1050	1160	1270	1380
M (mm)	570	660	705	763	866	966	1054	1153
L (mm)	154	165	190	190	203	216	216	254
a x b	18x11	18x11	22x14	22x14	22x14	22x14	22x14	28x16
ISO	F16	F25	F25	F25	F25	F25	F25	F30
Operating torque (Nm)	3450	5000	5500	6500	8500	11500	12000	15500
Weight (kg)	170,6	252	295	347	457	580	716	959

Data given can be changed without notice.

Edition 01/2018

ZETKAMA Sp. z o.o.
Ul. 3 Maja 12
PL 57-410 Ścinawka Średnia

Tel. +48 74 8652 193
Tel. +48 74 8652 111
Fax +48 74 8652 199

E-mail export@zetskama.com.pl
www.zetskama.com

FIG.495

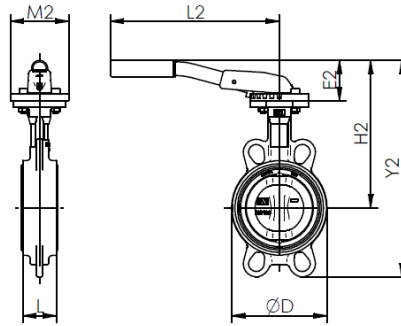

N	32	40	50	65	80	100	125	150	200
D (mm)	116	125	132	137	153	175	187	210	237
L (mm)	55	59	75	88	93	105	120	142	169
E 2 (mm)	33	33	43	46	46	52	56	56	60
H 2 (mm)	70	70	70	70	70	70	71	71	40
Y 2 (mm)	195	195	195	195	195	195	278	278	355
L 2 (mm)	73	82	90	103	120	152	180	207	260
M 2(mm)	65	65	65	65	65	65	90	90	125
Weight (kg)	50	50	50	50	50	50	70	70	102

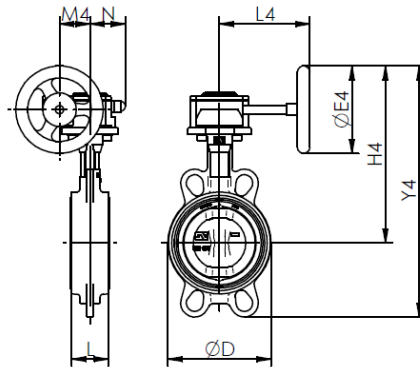

DN	D	L	E4	H4	Y4	L4	M4	N	Weight (kg)
32	68	33	125	190	250	129	43,5	50,5	2,8
40	76	33	125	198	254	129	43,5	50,5	2,9
50	100	43	125	208	269	129	43,5	50,5	3,7
65	108	46	125	223	282	129	43,5	50,5	4,0
80	124	46	125	229	323	129	43,5	50,5	4,4
100	147	52	125	253	359	129	43,5	50,5	5,2
125	180	56	160	286	412	135	43,5	50,5	7,6
150	206	56	160	298	431	135	43,5	50,5	8,7
200	257	60	200	355	525	152	52,5	59	13,7
250	324	68	250	442	652	222	61,5	70,5	23,7
300	376	78	250	468	708	222	61,5	70,5	33,0
350	422	78	250	498	762	222	61,5	70,5	38,7
400	480	102	300	572	880	277	68,8	72,5	64,5
450	538	114	400	630	970	321	96,5	91,5	99
500	593	127	400	682	1062	321	98,5	91,5	133
600	690	154	500	798	1239	408	138	140	208
700	780	185	500	914	1400	408	138	140	265
750	836	190	600	944	1474	456	138	140	271
800	902	190	700	1044	1608	510	180	156	408
900	1010	203	700	1108	1718	510	180	156	521
1000	1116	216	700	1184	1858	579	180	156	648
1100	1215	216	700	1250	1962	593	252	226	913
1200	1324	254	700	1310	1983	593	252	228	1161

Data given can be changed without notice.

Edition 01/2018

ZETKAMA Sp. z o.o.
 Ul. 3 Maja 12
 PL 57-410 Ścinawka Średnia

Tel. +48 74 8652 193
 Tel. +48 74 8652 111
 Fax +48 74 8652 199

E-mail export@zetskama.com.pl
 www.zetskama.com

KV [m³/h] DEPENDING OF ANGLE OPENING DISC

DN	90°	80°	70°	60°	50°	40°	30°	25°
32	45	37	29	19	12	6	2	-
40	68	60	38	22	15	9	4,3	2,5
50	112	90	60	45	23	14	7,7	5
65	172	138	90	70	36	22	12,9	8,6
80	258	207	138	110	54	33	19	13
100	474	410	260	200	103	63	36	24
125	970	860	540	420	215	133	76	52
150	1680	1420	890	690	353	215	146	125
200	2800	2350	1510	1120	603	360	215	146
250	4310	3700	3190	1850	990	580	336	224
300	6465	5215	3490	2670	1380	860	475	327
350	8620	6980	4395	3535	1896	1120	645	430
400	10775	9310	5600	4395	2285	1465	775	560
450	15086	12700	7930	6120	3190	1980	1077	775
500	18965	15085	9900	7500	3965	2415	1380	970
600	24137	20700	14225	10130	5260	3275	1895	1293
700	36000	25300	17100	10600	5980	3860	1990	1350
750	40500	27400	18400	11450	7150	4350	2125	1560
800	44000	29000	20000	12500	8200	4500	2200	1600
900	58000	42000	29000	17500	10400	6100	2300	1800
1000	80500	59200	37500	23000	13500	8700	3800	2500
1100	97586	72540	54560	28560	18210	10560	6350	4450
1200	110500	82000	61500	35500	22600	12500	7800	5400

OPERATING TORQUE IN NM TO CLOSE THE VALVES DEPENDING ΔP (BAR)

DN	3 bar	6 bar	10 bar	16 bar
32	5	6	9	15
40	5	6	9	15
50	5	7	13	17
65	15	16	20	25
80	17	20	23	28
100	22	29	42	50
125	39	46	72	85
150	48	75	90	110
200	90	120	140	215
250	126	210	270	350
300	161	270	390	560
350	245	300	500	950
400	520	600	700	1000
450	590	1120	1450	1950
500	840	1390	1800	2500
600	1000	2200	3450	3800
700	1650	3300	5000	5860
750	1800	3500	5500	6000
800	2300	4600	6500	9500
900	4700	6800	8500	11500
1000	6500	8500	11500	15000
1100	7000	9000	12000	16000
1200	8500	12000	15500	22000

Data given can be changed without notice.

Edition 01/2018

PART'S MATERIALS

Disc

Material	Standard	Application
Stainless steel	1.4308	Chemical products/ nourishing products
Stainless steel	1.4408	Demineralized water/ chemical products/ nourishing products
Stainless steel	1.4404	Chemical and nourishing products/ sea water/ demineralized water
Aluminium	En-AC-44100	Cold water/ air
Bronze tin	CuSn10-C	Sea water
Bronze-aluminium	CuAl10Fe5Ni5-C	Sea water
Cast steel	GP240GH	Water/ gas
Nodular cast iron	EN-GJS-400-15 5.3106	Hot water / air/ gas
Nodular cast iron + EPDM	EN-GJS-400-15 + EPDM 5.3106	Powdery products/ pneumatic transport/ sea water
Duplex	1.4517	Chemical products
Superdupleks	1.4469	Sea water/ corrosive atmospheres

Seat

Material	Application	Temperature range	
EPDM (Ethylene propylene)	Water/ sea water/ weak acids and basis / glycol	-40°C	+110°C
EPDM HT (EDM high temp.)	Heating without steam water	+80°C	+130°C
NBR (nitrile)	Mineral oils/ vegetables oils/ greases	-40°C	+90°C
Flucast AB/P	Abrasive powdered products	-10°C	+90°C
Flucast AB/E	Oxygenated solvents ketones esters with abrasion	-20°C	+95°C
Flucast AB/N	Mineral oils/ vegetables oils/ greases/ abrasives	-10°C	+100°C
Silicone	Air and hot water without steam	-60°C	+200°C
Food silicone	Nourishing and milky products	-60°C	+200°C
Steam silicone	steam	-60°C	+140°C
Viton	Acids/ high temperature	-15°C	+210°C
Biodisel Viton	Biodiesel	-5°C	+210°C
Viton GF Gasoline	Oxygenate gasoline	-5°C	+210°C
Hypalon	Water/ diluted bases	-25°C	+120°C
Epichlorohydrin	Brine systems	-40°C	+125°C
Neoprene	Sea water	-25°C	+80°C
Butyl	Gas	-10°C	+95°C
Flucast extreme	Water / steam / acids	-5°C	+200°C

Data given can be changed without notice.

Edition 01/2018

TYPE

Figure	Body material	Nominal diameter	Nominal pressure	Type
495	A Grey cast iron EN-GJL-250	32-150 mm	C 16 bar	66 disc - ductile iron; covered by epoxy layer; EPDM sealing; catch lever
		200-300 mm	B 10 bar	66 disc - ductile iron; covered by epoxy layer; EPDM sealing; catch lever
		350-1200 mm	B 10 bar	26 disc - ductile iron; covered by epoxy layer; EPDM sealing; bare shaft – for the actuator
		32-150 mm	C 16 bar	36 disc - stainless steel; EPDM sealing; catch lever
		200-300 mm	B 10 bar	36 disc - stainless steel; EPDM sealing; catch lever
		350-1200 mm	B 10 bar	06 disc - stainless steel; EPDM sealing; , bare shaft - for the actuator
495	B Nodular cast iron EN-GJS-400-15	32-150 mm	C 16 bar	66 disc - ductile iron; covered by epoxy layer; EPDM sealing; catch lever
		200-300 mm	B 10 bar	66 disc - ductile iron; covered by epoxy layer; EPDM sealing; catch lever
		350-1200 mm	B 10 bar	26 disc - ductile iron; covered by epoxy layer; EPDM sealing; bare shaft – for the actuator
		32-150 mm	C 16 bar	36 disc - stainless steel; EPDM sealing; catch lever
		200-300 mm	B 10 bar	36 disc - stainless steel; EPDM sealing; catch lever
		350-1200 mm	B 10 bar	06 disc - stainless steel; EPDM sealing; , bare shaft - for the actuator

ORDERING

Figure	Body material	Nominal diameter	Nominal pressure	Type
495	A Grey cast iron EN-GJL-250	32-150 mm	C 16 bar	66 disc - ductile iron; covered by epoxy layer; EPDM sealing; catch lever

Order example acc. index

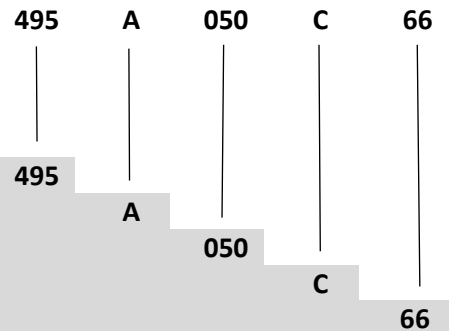

Butterfly valve, ends wafer type, form straight
 Grey cast iron EN-GJL-250
 Nominal diameter (mm)
 Nominal pressure PN 16
 Disc - ductile iron; covered by epoxy layer; EPDM sealing; catch lever

Data given can be changed without notice.

Edition 01/2018